

Stone Coated Steel Roofing Tile



Hollyland

Hebei Hollyland Co.,Ltd.
[Http://www.hollyland.net.cn](http://www.hollyland.net.cn)



Hollyland Hebei Hollyland Co.,Ltd.

Brief Introduction

HEBEI HOLLYLAND CO., LTD, was established in 2003, specialize in producing and exporting Stone Coated Steel Roofing Tiles. Our manufactory has strong technical strength and advanced equipment.

The Stone Coated Steel Roofing Tiles we produced with variety colors, have the features of no fading, light weight, water proof, reduce noise when raining, resistance of earthquake, fire & typhoon, very easy to be installed, convenient to be maintained, and comfortable to be used and etc.

We have passed the ISO9001:2000, the CE certification and SONCAP !

The products are exported to the markets of Southeast Asia, Africa, the Middle East and other parts of the world.

We also have a professional team to handle your orders, could meet or exceed your quality requirement, control the delivery date, packing and loading, handle any kinds of shipment by sea or air .

Enough experience have been accumulated during the years in our business, so that we can help you to reduce your International Sourcing Cost, and increasing your bottom line!

Our Mission: Your success is our target!

STANDARDS ORGANISATION OF NIGERIA
SONCAP

Page 1/3

PRODUCT Certificate

STANDARDS ORGANISATION OF NIGERIA CONFORMITY ASSESSMENT PROGRAM

Product Certificate No.: FV1020903078(CNOR)
Issued to: HEBEIHOLLYLANDCO.,LTD
Issue date: 24.05.2011 Date of assessment: 20.09.2011

Remarks:
ISO 9001:2008 CERTIFICATE NO. C10588611035CM VALID UNTIL 05.09.2013
TEST REPORT DATED 14.4.09.2011

Issued by:
DQS-QTC Danacerta Technical Services Co., Ltd. - Shanghai - China
HENRY FUJIA

SONCAP manager (SGS)



This Product Certificate is for exclusive use of DQS's Client and is provided pursuant to the agreement between DQS and its Client. DQS's responsibility and liability are limited to the terms and conditions of the agreement. DQS assumes no liability to any party other than the Client in accordance with the agreement, for any loss, expense or damage sustained by the use of this Product Certificate. Only the Client is authorized to permit copying or distribution of this Product Certificate and Fee only in its territory. Any use of the SGS's name for the sake of advertisement of the tested material, product of service must be approved in writing by SGS.

SMQ Shenzhen Academy of Metrology and Quality Inspection Safety Laboratory
Add: Bldg of Metrology & Quality Inspection , Longzhu Road, Nanshan District, Shenzhen, Guangdong, China

CERTIFICATE

No: 511171-DZ/GG

Applicant: Hebei Hollyland Co., Ltd
Address: 14F, Building A, Zhongliang Plaza, No.345 Youyi North Street Shijiazhuang, Hebei Province, China
Product: Colorful Stone Coated Metal Roof Tile
Model No.: N/A
Test Standard: EN 508-3: 2009

The EUT described above is tested in Shenzhen Academy of Metrology and Quality Inspection Safety Laboratory. The safety laboratory is assumed full responsibility for the accuracy of the test results. The certificate shows that the EUT technically complies with the council 89/106/EEC directive requirements.

The certificate applies to the tested sample above mentioned only and shall not imply an assessment of the whole production.

Authorized Signer: 
Issued Date: 10/14/2011





ITME NO.: HL1101 ; HL1102

Type	Model No.	HL1101	HL1102
Classical Tile	Tile Size	1340mm*420mm	1170mm*420mm
	Installed Exposure	1290mm*370mm	1080mm*370mm
	Tiles per Sqm	2.08 Sheets	2.5 Sheets
	Installed Weight	2.8kg/Sheet	2.4kg/Sheet





ITME NO.: HL1103

Type	Model No.	HL1103
Ripple Tile	Tile Size	1340mm*420mm
	Installed Exposure	1290mm*370mm
	Tiles per Sqm	2.08 Sheets
	Installed Weight	2.8kg/Sheet





ITME NO.: HL1104

Type	Model No.	HL1104
Shingle Tile	Tile Size	1340mm*420mm
	Installed Exposure	1290mm*370mm
	Tiles per Sqm	2.08 Sheets
	Installed Weight	2.8kg/Sheet





Hollyland ROMAN TILE

Hebei Hollyland Co.,Ltd.



ITME NO.: HL1105

Type	Model No.	HL1105
Roman Tile	Tile Size	1300mm*420mm
	Installed Exposure	1250mm*370mm
	Tiles per Sqm	2.16 Sheets
	Installed Weight	3.0kg/Sheet



Hollyland MILANO TILE

Hebei Hollyland Co.,Ltd.



ITME NO.: HL1107

Type	Model No.	HL1107
Milano Tile	Tile Size	1350mm*420mm
	Installed Exposure	1300mm*370mm
	Tiles per Sqm	2.08 Sheets
	Installed Weight	2.7kg/Sheet





ITME NO.: HL1106

Type	Model No.	HL1106
Wooden Tile	Tile Size	1340mm*420mm
	Installed Exposure	1290mm*370mm
	Tiles per Sqm	2.08 Sheets
	Installed Weight	2.8kg/Sheet



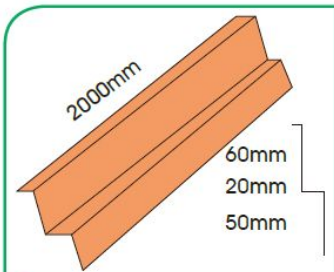
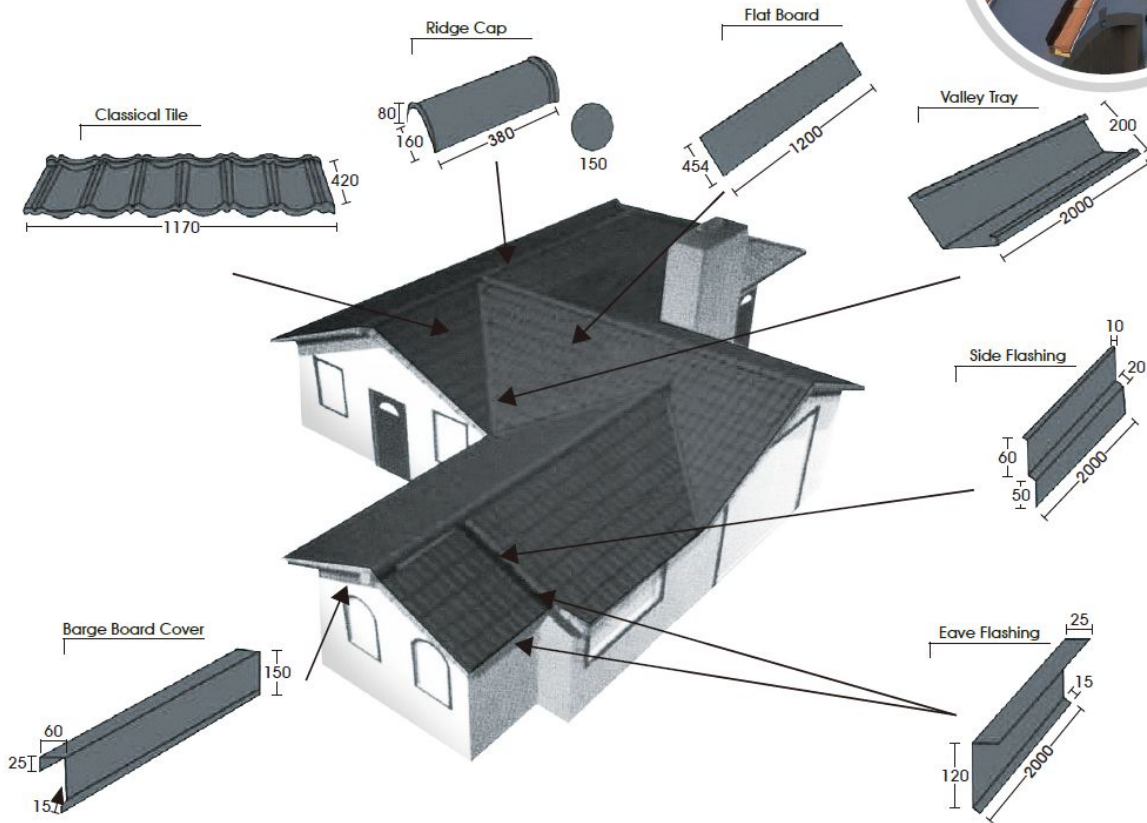

Wall Side Flashing

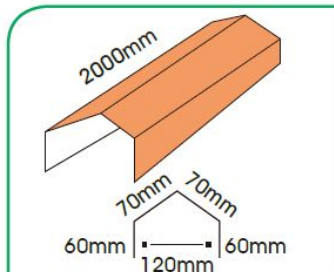

Angle Rige Cap

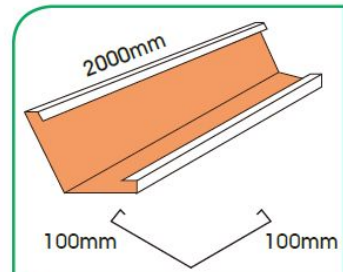

Valley Tray

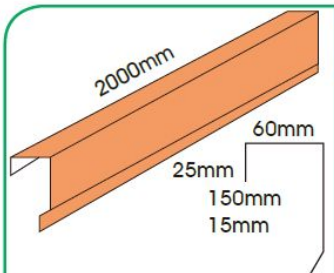

Barge Board Cover

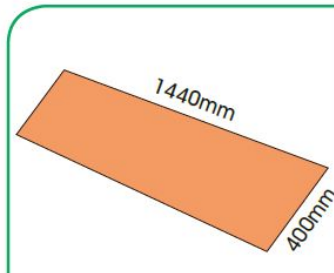

Flat Board

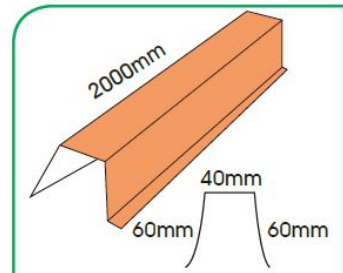

Square Rige Cap

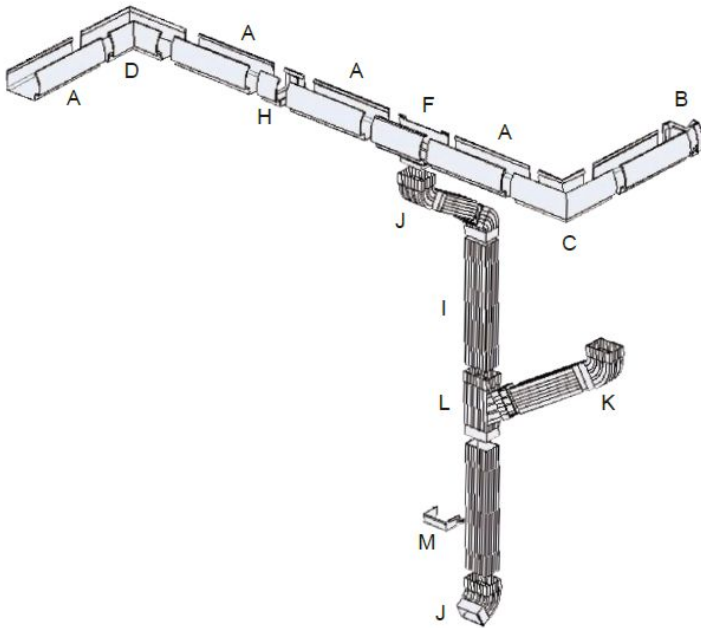

No.	Name
A	Gutter
B	End Cap
C	Outside Coner 90°
D	Intside Coner 90°
E	Gutter Hanger
F	Drop Outlet
H	Connector
I	Down Spout
J	Elbow
K	Redirector
L	Lateral Tee
M	Downspout Clip



Ⓐ GUTTER



Ⓑ LEFT ENDCAP



Ⓑ2 RIGHT ENDCAP

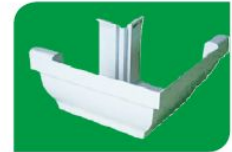

Ⓒ OUTSIDE CONER 90°



Ⓓ INSIDE CONER 90°



Ⓔ GUTTER HANGER



Ⓕ DROP OUTLET



Ⓖ CONNECTOR

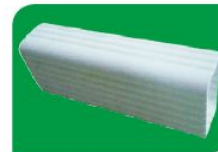

Ⓘ DOWN SPOUT



Ⓙ ELBOW



Ⓚ REDIRECTOR



Ⓛ LATERAL TEE



Ⓜ DOWN SPOUT CLIP



Ⓜ2 DOUBLE SPOUT CLIP



STONE COATED STEEL ROOFING TILE

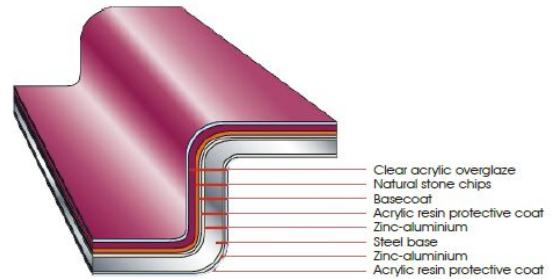

All tile coatings are applied after pressing, there are no problems with crazing or micro-cracking.

Advantages of stone coated steel roofing tile

● Economy

The Stone Coated Roofing Tile has big coverage. It can cut down the cost of physical distribution and installation. Once installed, later maintenance cost very little, almost negligible.

● Simple Construction

The Stone Coated Roofing Tile has light weight. It's very easy to cut and bend. It could also be fastened on the wooden or steel battens, so it's suitable for all kinds of buildings.

● Recycling

The base board of the Stone Coated Steel Roofing Tile is Zinc-aluminum steel. 90% ingredients can be recycled, then reduce building cost.

● Long Lifetime

The Zinc-aluminum steel has high corrosion resistance. It has excellent durability with multilayer protective films. Its life span can be extended to 30 years!

● Beautiful Appearance

The surface of Stone Coated Roofing Tile are natural stone chips in various colors. Extensive flexibility of colors and profiles provide various building design.

● Fire Resistance

The main materials are Zinc-aluminum steel and natural stone which have strong fire resistance.

● Storm Resistance

No leakage occurs after prolonged exposure test. It could also reduce the noise when raining.

● Heavy Wind Resistance

It is installed by horizontal nailing method which could prevent the tiles lifted up in heavy wind.

● Hail Resistance

Stone Coated Steel Roofing Tile can resist cold, frost and slip etc. It can also reduce the weight of snow on the building.

● Earthquake Resistance

The weight of Stone Coated Steel Roofing Tile is just one sixth of traditional concrete or clay tile. It could lighten the building and has excellently resistant ability.

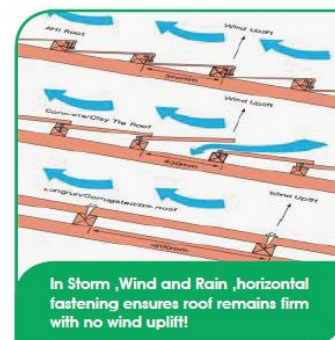
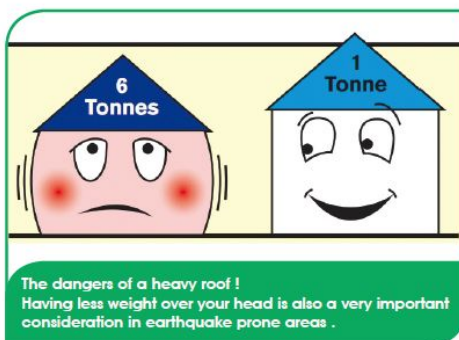



HLC201 (Iron Oxide Red)



HLC202 (Black)



HLC203 (Black & Blue)



HLC204 (Garnet)



HLC205 (Coffee & Brown)



HLC206 (Brick)



HLC207 (Black & White)



HLC208 (Black & Coffee)



HLC209 (Greenstone)



HLC210 (Sky Blue)



HLC211 (Ravine)



HLC212 (Black & Green)

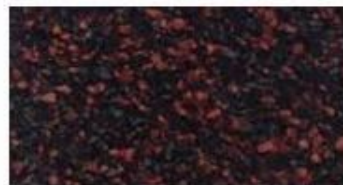

HLC213 (Black & Red)



HLC214 (Coffee)



HLC215 (Teak)



HLC216 (Auburn)



HLC217 (Beige Red)



Classical



Roman



Ripple



Milano

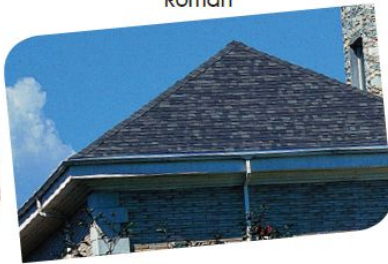

Shingle



Wooden



Hollyland Stone Coated Steel Roofing Tile
Hebei Hollyland Co., Ltd.

14F, Building A, Zhongliang Plaza, No.345 Youyi North Street,
Shijiazhuang, China 050061

Tel: 86-311-6800 1028; 86-311-68001003

Mobile: 18731122692

Fax: 86-311-6800 1016

Website: <http://www.hollyland.net.cn/>

Email: sales2@hollyland.net.cn

Skype: hollylandyy ; QQ: 1963831226